

**bobo chic**  
PARIS

**NOTICE DE MONTAGE**  
**ASSEMBLING INSTRUCTIONS**  
**MANUAL DE MONTAJE**  
**INSTRUÇÕES DE INSTALAÇÃO**  
**MONTAGEANLEITUNG**  
**ISTRUZIONI DI MONTAGGIO**

# NINA

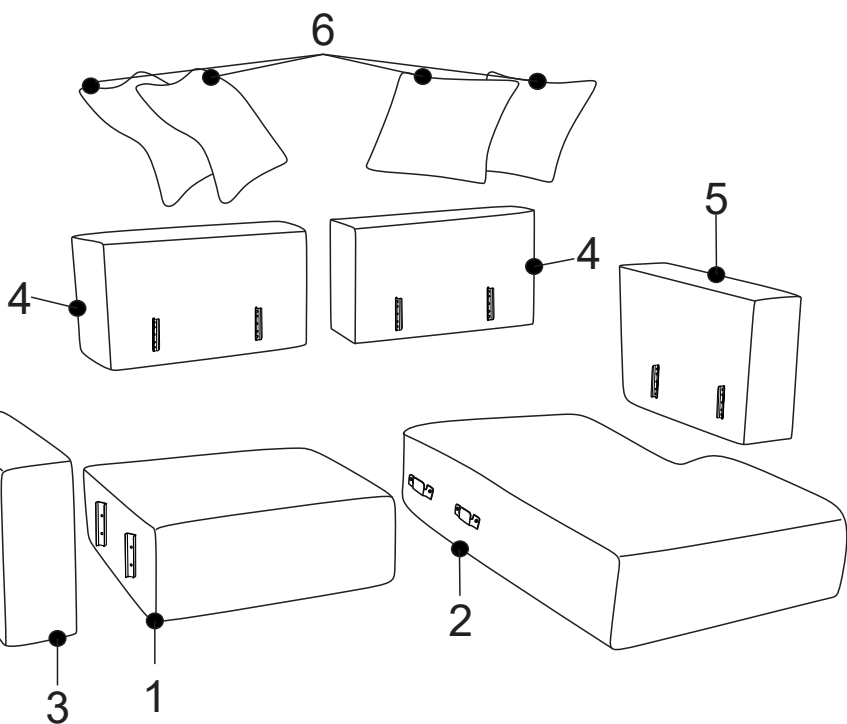
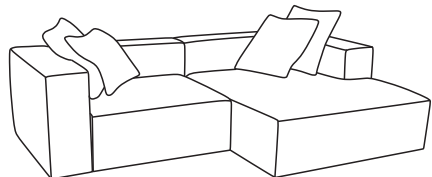

I

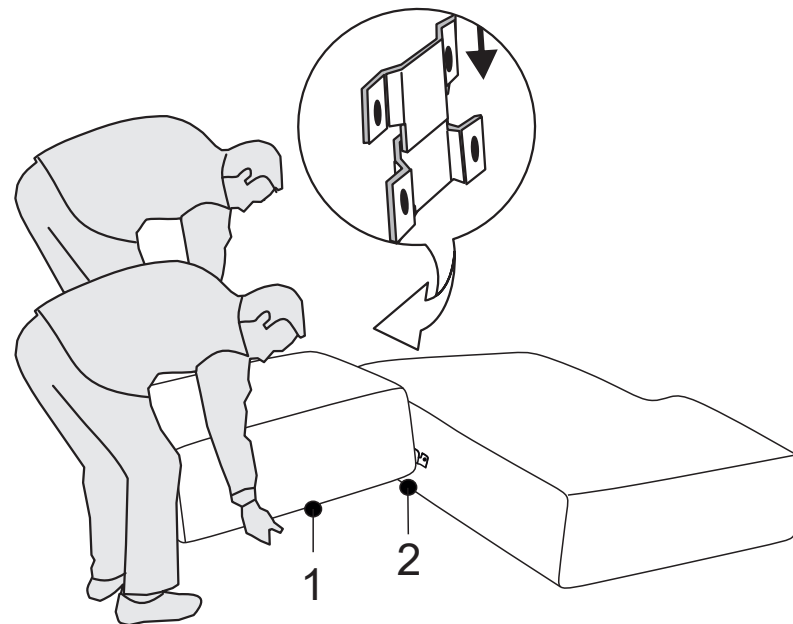

II

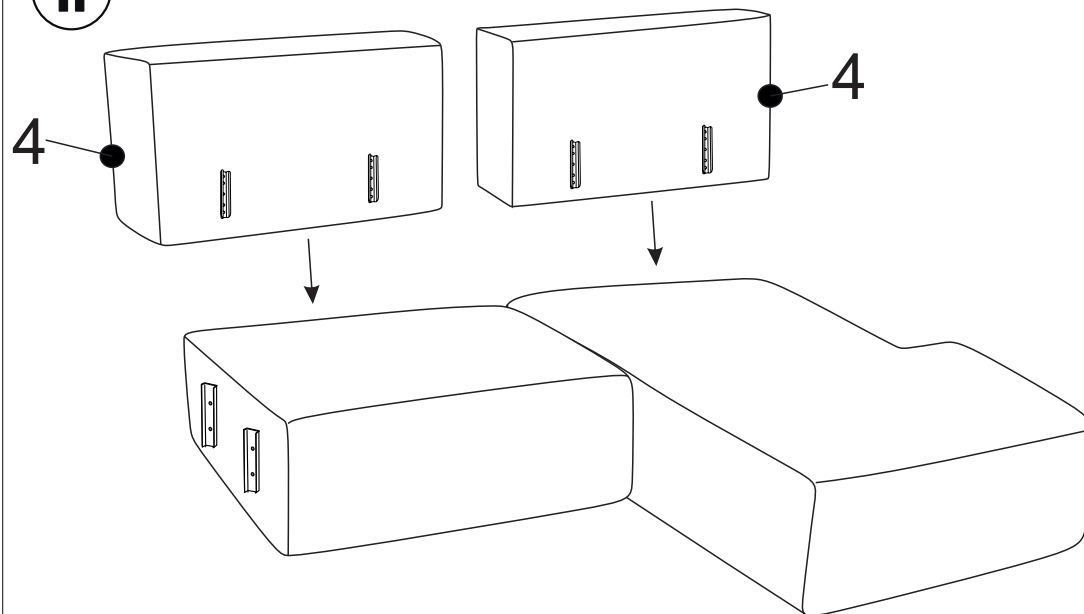

III

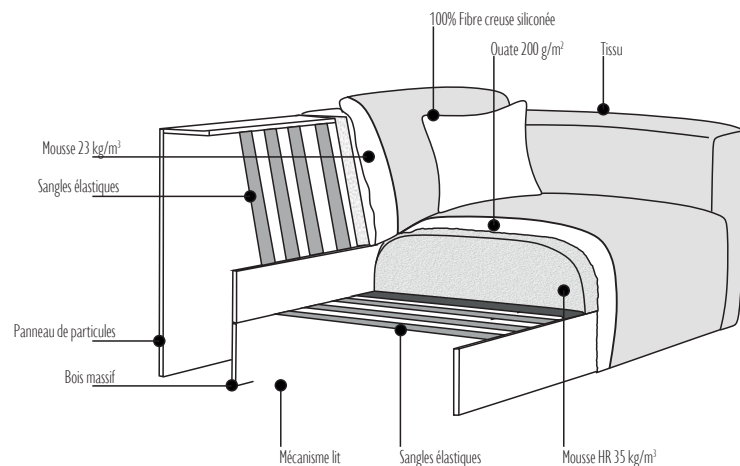
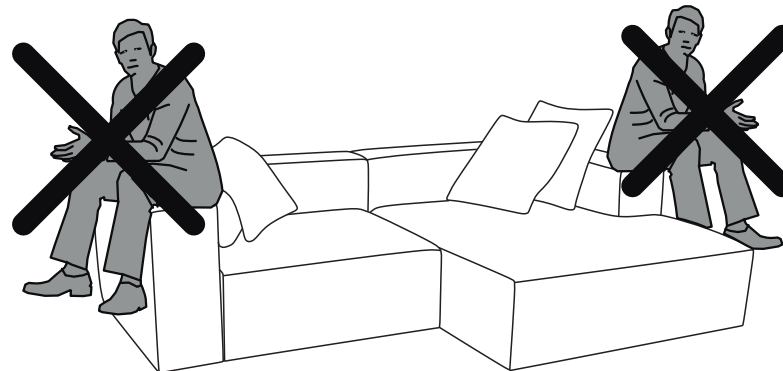
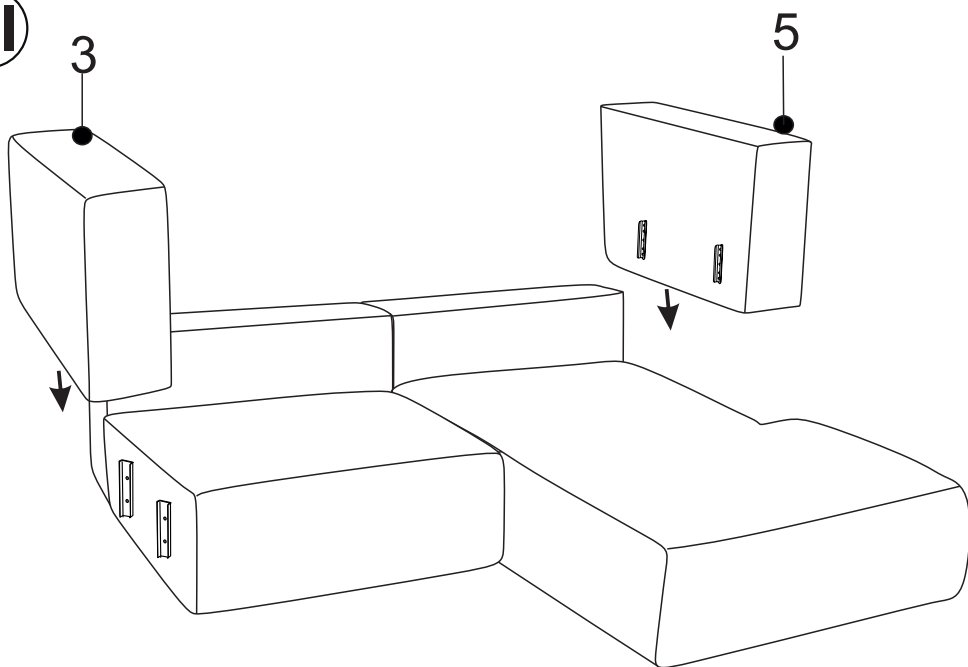

IV

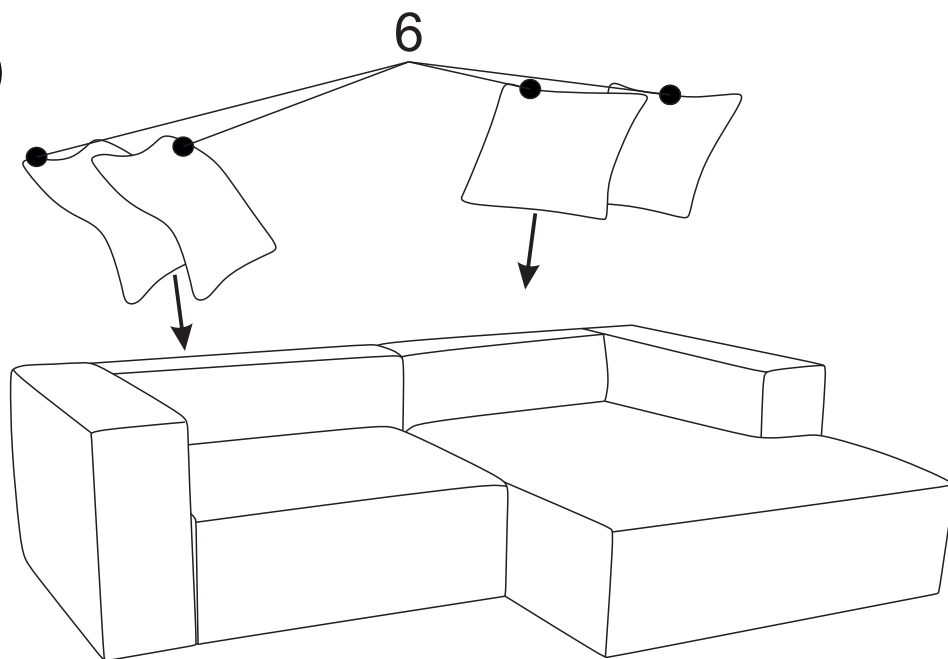

Le boulochage du tissu est une caractéristique normale et ne peut pas être éliminé.  
Pour des raisons technologiques, les différences de nuances de couleurs sont acceptables.

Fabric pilling is a normal feature and cannot be eliminated.  
For technological reasons, differences in color shades are allowed.

El pilling de la tela es una característica normal y no se puede eliminar.  
Por razones tecnológicas, se permiten diferencias en los tonos de color.

O pilling do tecido é uma característica normal e não pode ser eliminado.  
Por razões tecnológicas, são permitidas diferenças de tonalidades de cores.

Pilling ist eine natürliche Eigenschaft des Stoffes und kann nicht ausgeschlossen werden.  
Unterschiede in den Farbtönen sind aus technischen Gründen zulässig.

Il pilling sui tessuti è una caratteristica normale e non può essere eliminata.  
Per ragioni tecnologiche sono ammesse differenze di tonalità di colore.



LE TRI  
+ FACILE



BAC  
DE  
TRI

**bobo chic**  
PARIS

**NOTICE DE MONTAGE**  
ASSEMBLING INSTRUCTIONS  
**MANUAL DE MONTAJE**  
INSTRUÇÕES DE INSTALAÇÃO  
**MONTAGEANLEITUNG**  
ISTRUZIONI DI MONTAGGIO

# NINA

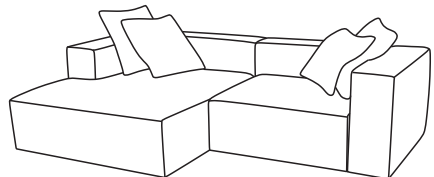

6

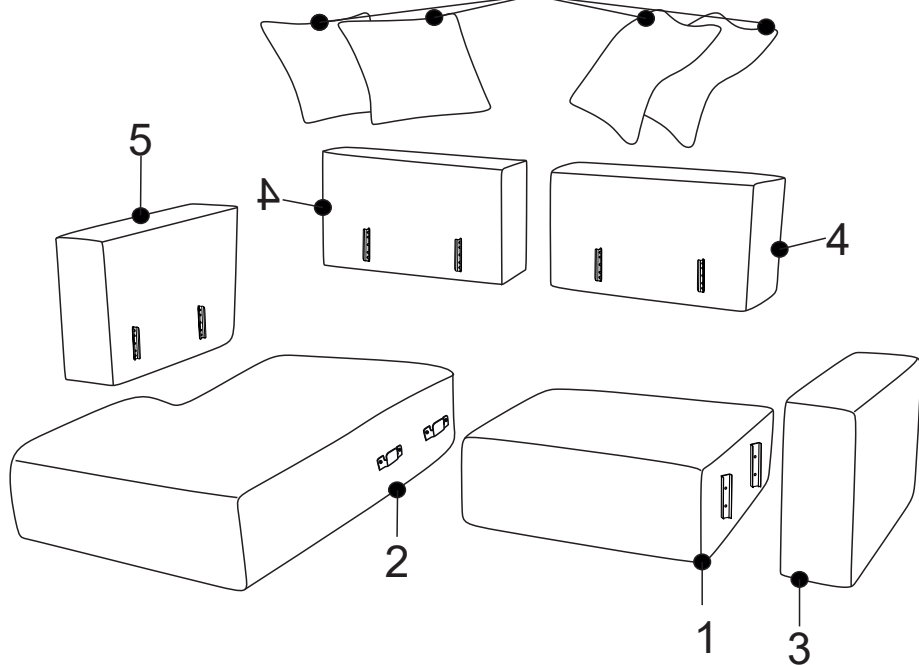

I

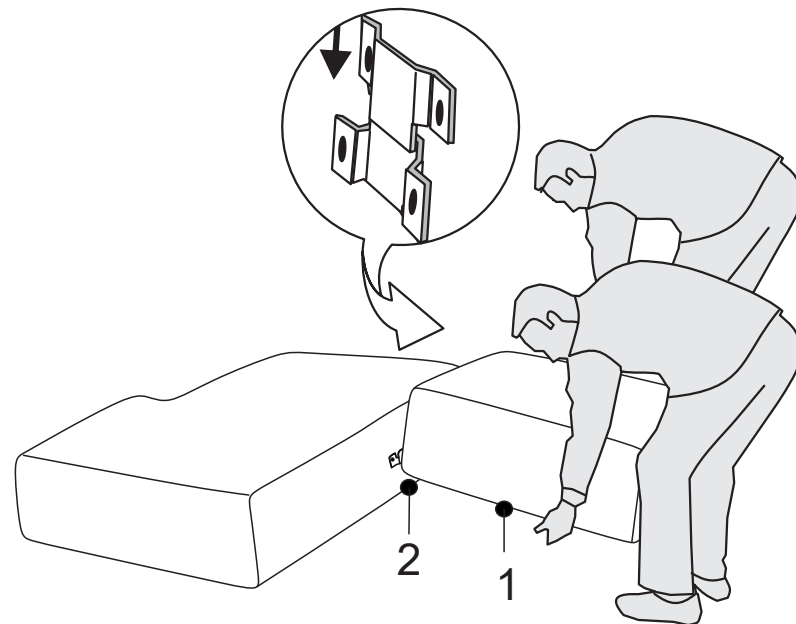

II

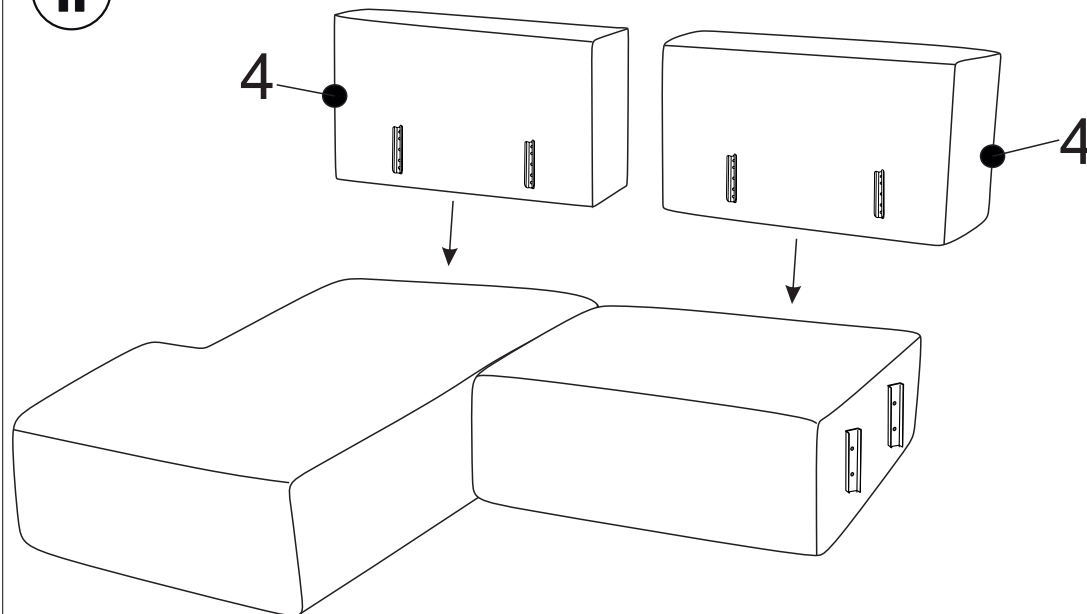

III

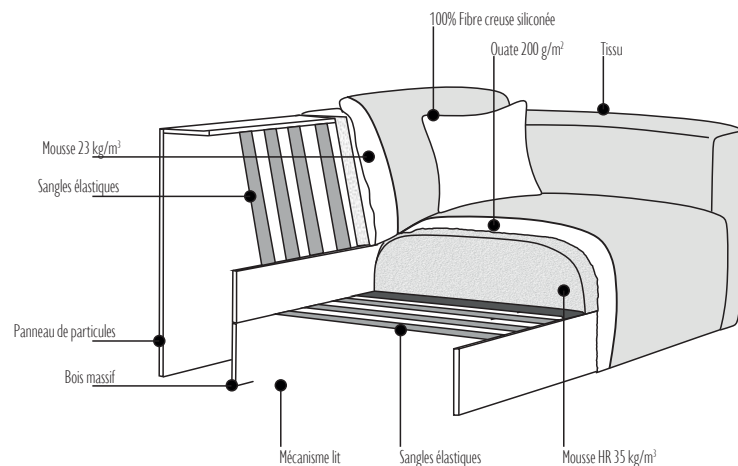
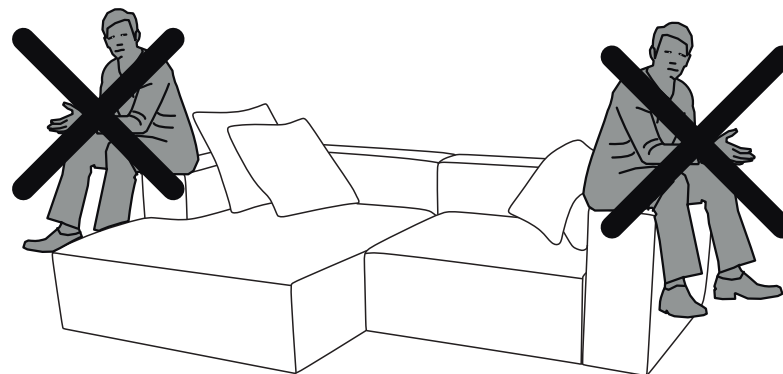
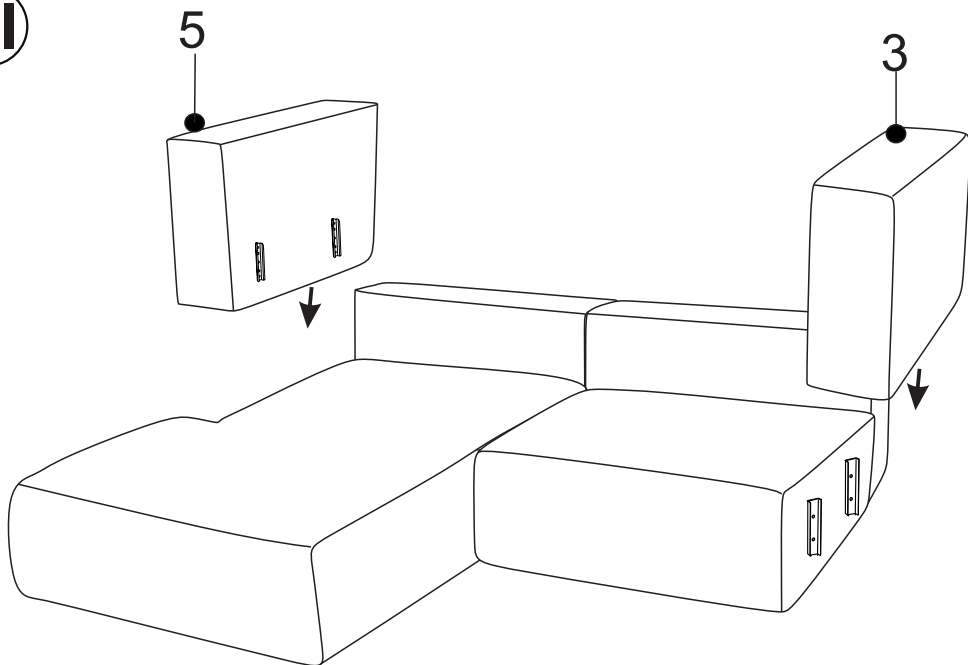

IV

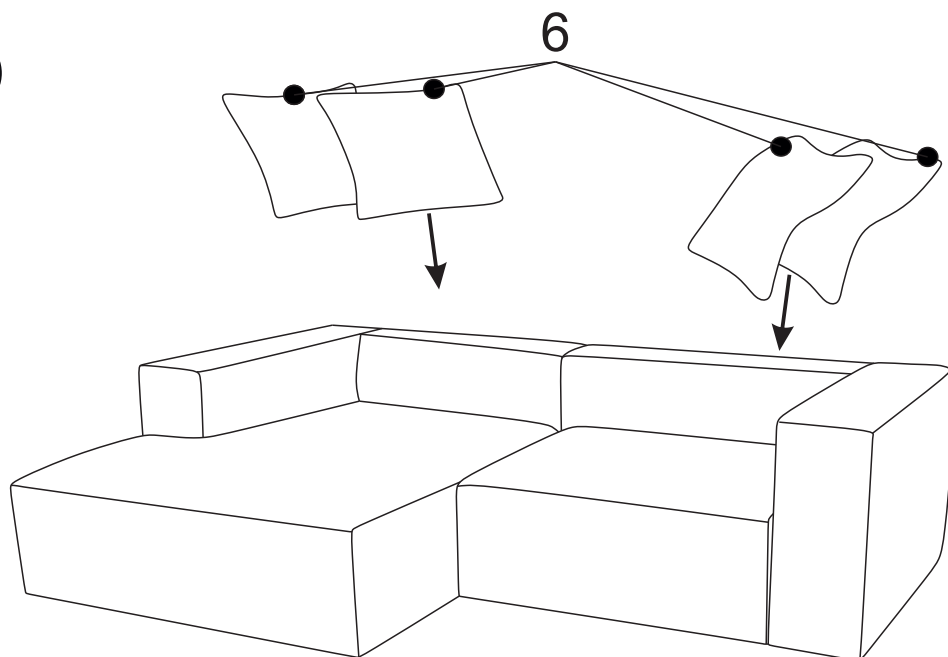

Le boulochage du tissu est une caractéristique normale et ne peut pas être éliminé.  
Pour des raisons technologiques, les différences de nuances de couleurs sont acceptables.

Fabric pilling is a normal feature and cannot be eliminated.  
For technological reasons, differences in color shades are allowed.

El pilling de la tela es una característica normal y no se puede eliminar.  
Por razones tecnológicas, se permiten diferencias en los tonos de color.

O pilling do tecido é uma característica normal e não pode ser eliminado.  
Por razões tecnológicas, são permitidas diferenças de tonalidades de cores.

Pilling ist eine natürliche Eigenschaft des Stoffes und kann nicht ausgeschlossen werden.  
Unterschiede in den Farbtönen sind aus technischen Gründen zulässig.

Il pilling sui tessuti è una caratteristica normale e non può essere eliminata.  
Per ragioni tecnologiche sono ammesse differenze di tonalità di colore.



LE TRI  
+ FACILE



BAC  
DE  
TRI