

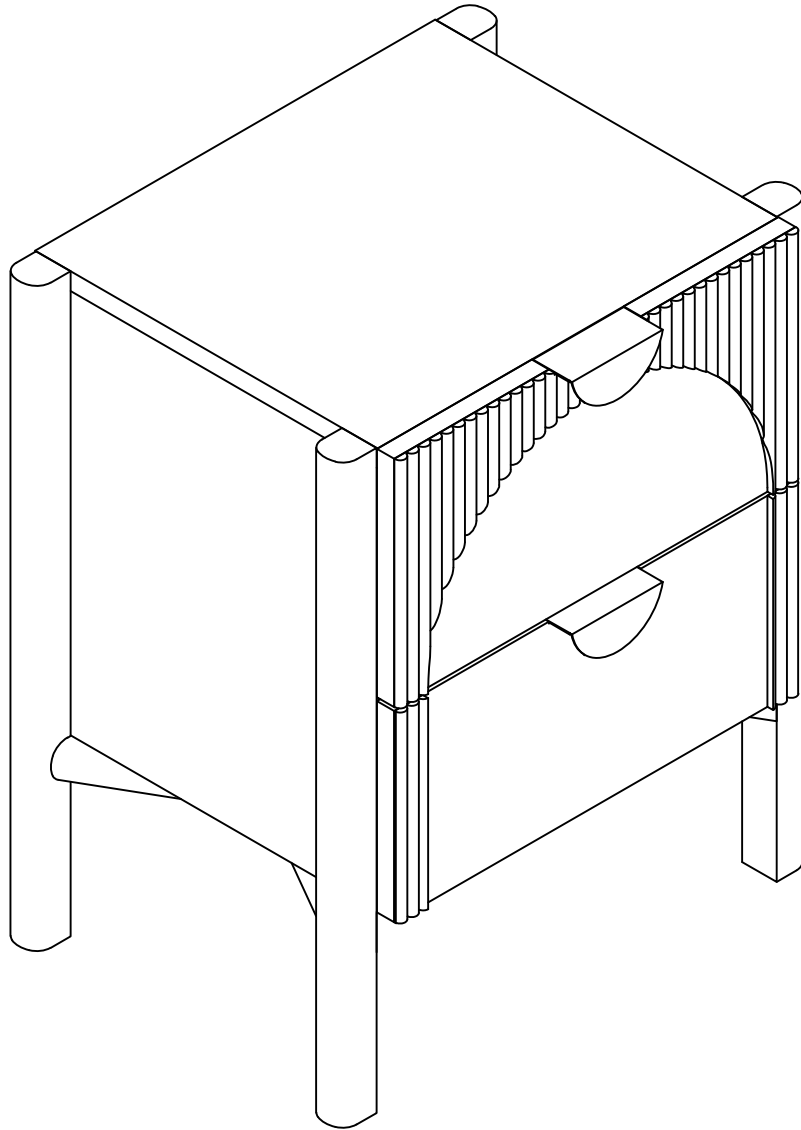

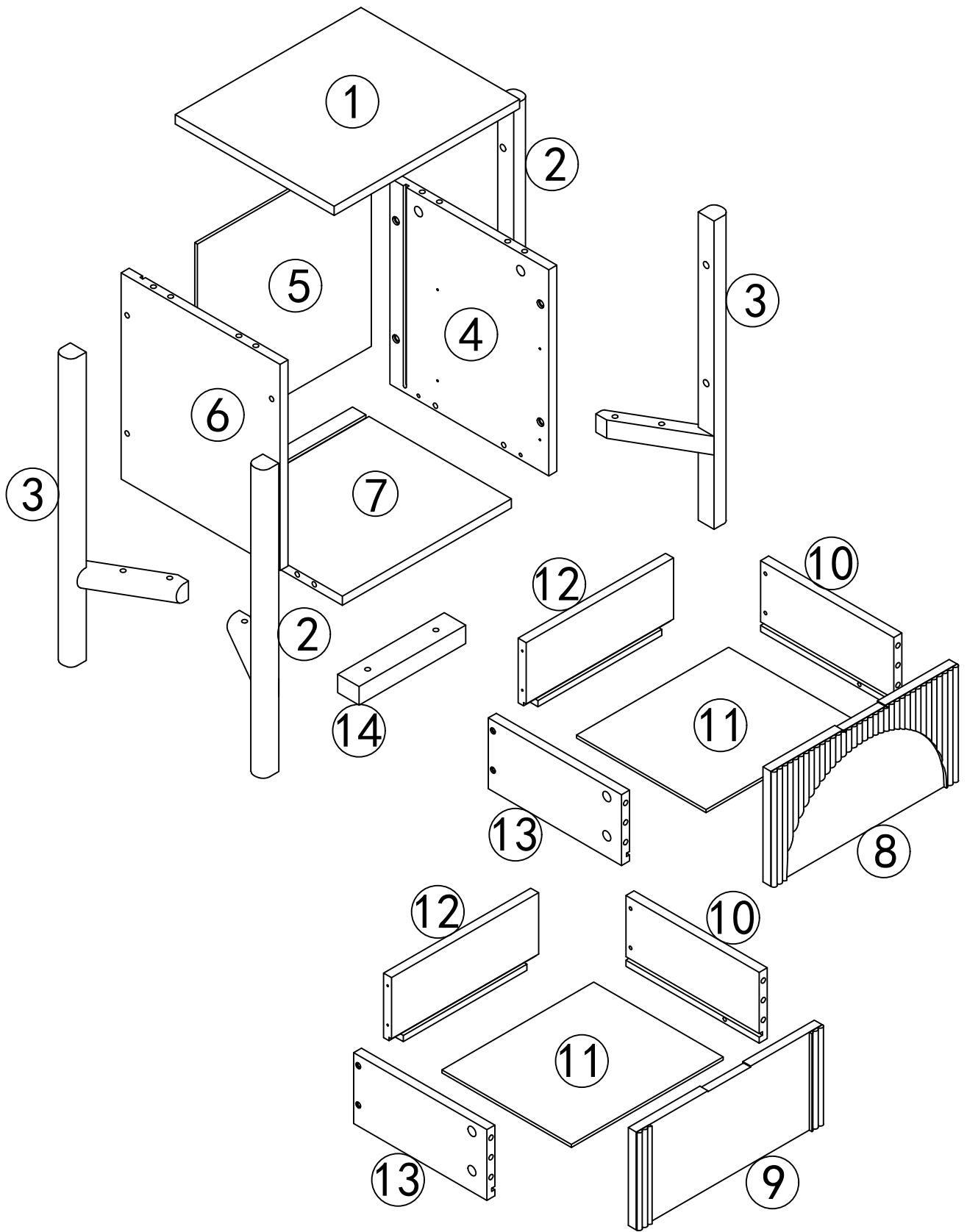











# Assembly instruction

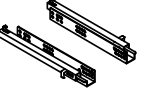



<p>A</p>  x16	<p>B</p>  x16 $\varnothing 15 \times 11.5 \text{mm}$	<p>C</p>  x12 $\varnothing 8 \times 30 \text{mm}$	<p>D</p>  x8 M4 $\times$ 35mm	<p>E</p>  x10 M6 $\times$ 38mm	<p>F</p>  x8 M6 $\times$ 22mm	<p>G</p>  x2
<p>H</p>  x4 M3.5 $\times$ 14mm	<p>I</p>  x2	<p>J</p>  x12 M3.5 $\times$ 12mm	<p>K</p>  x4	<p>L</p>  x4 M3.0 $\times$ 14mm	<p>M</p>  x4 25 $\times$ 25 $\times$ 3mm	<p>N</p>  x1 M4

Step:1

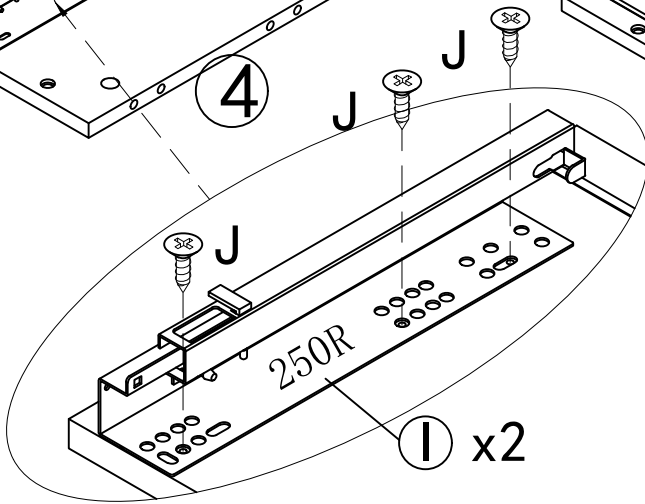
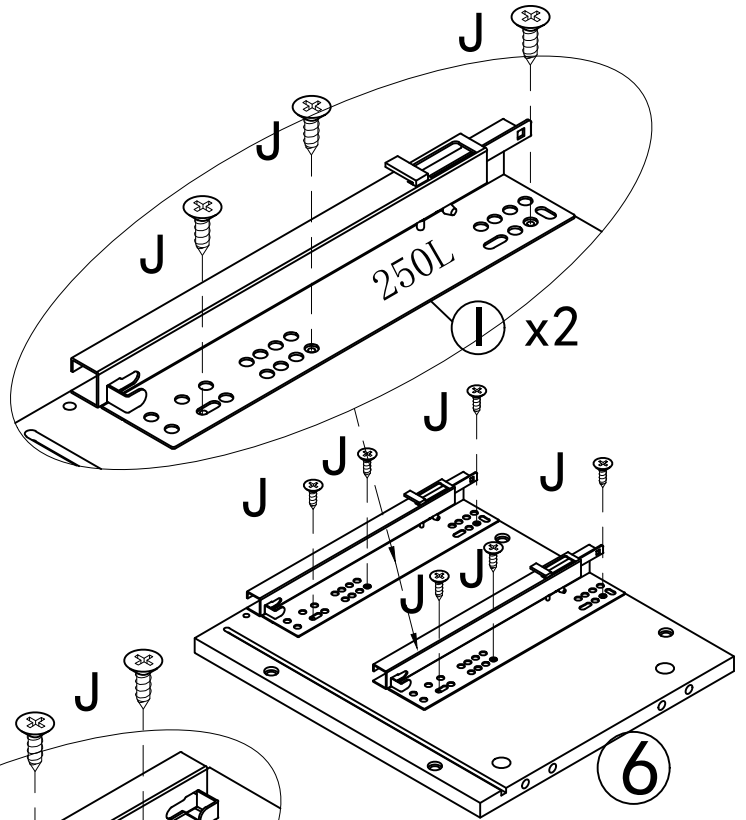
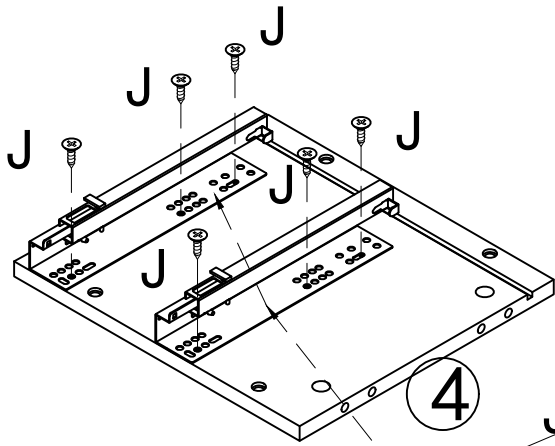
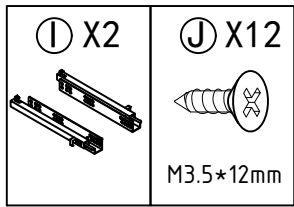

Step:2

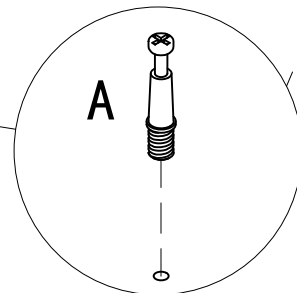
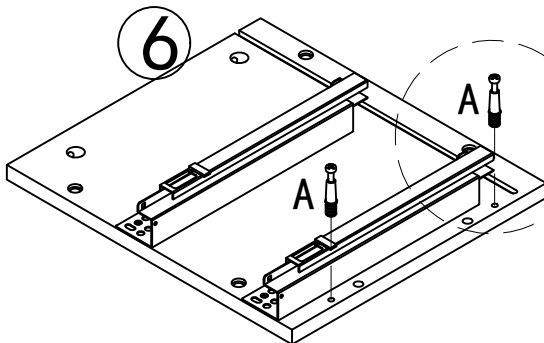
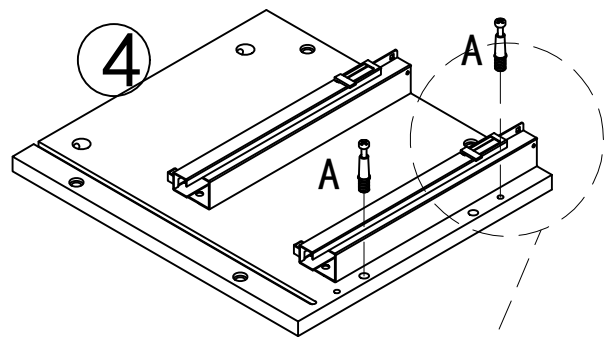
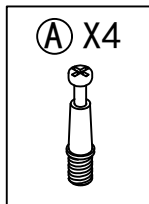

Step:3

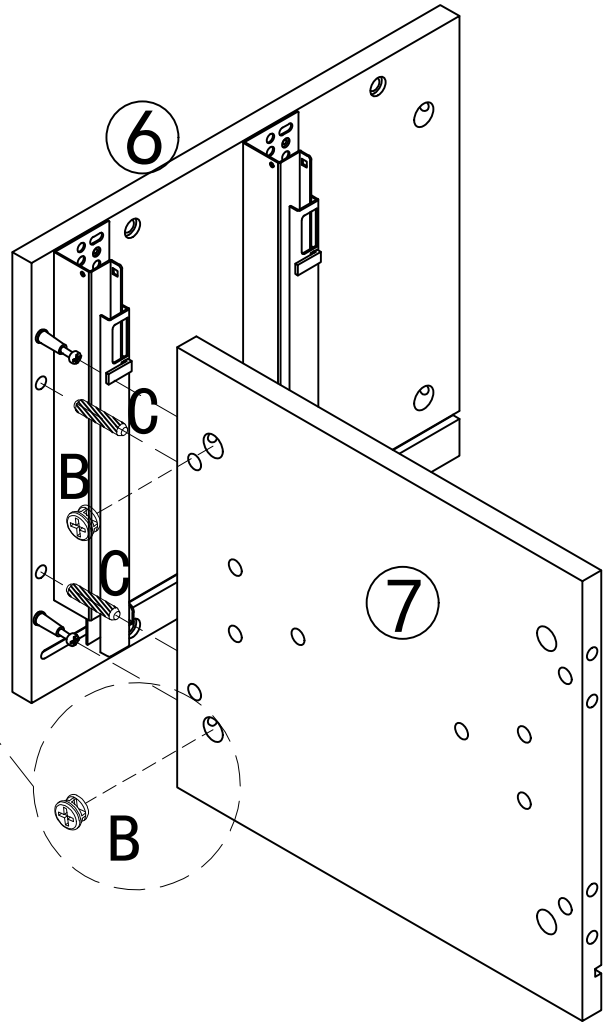
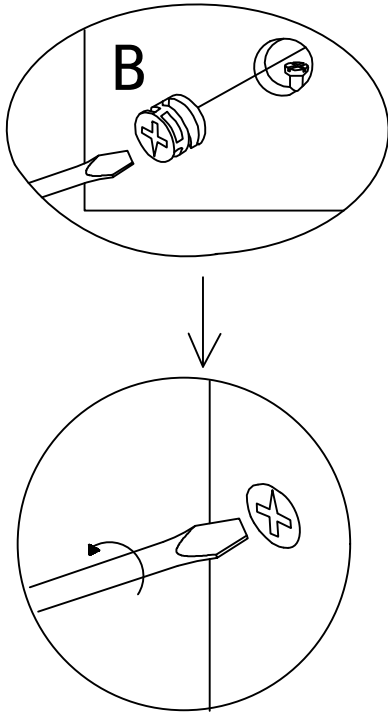
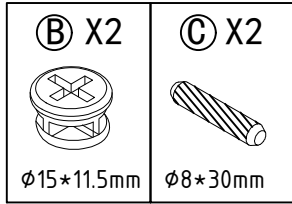

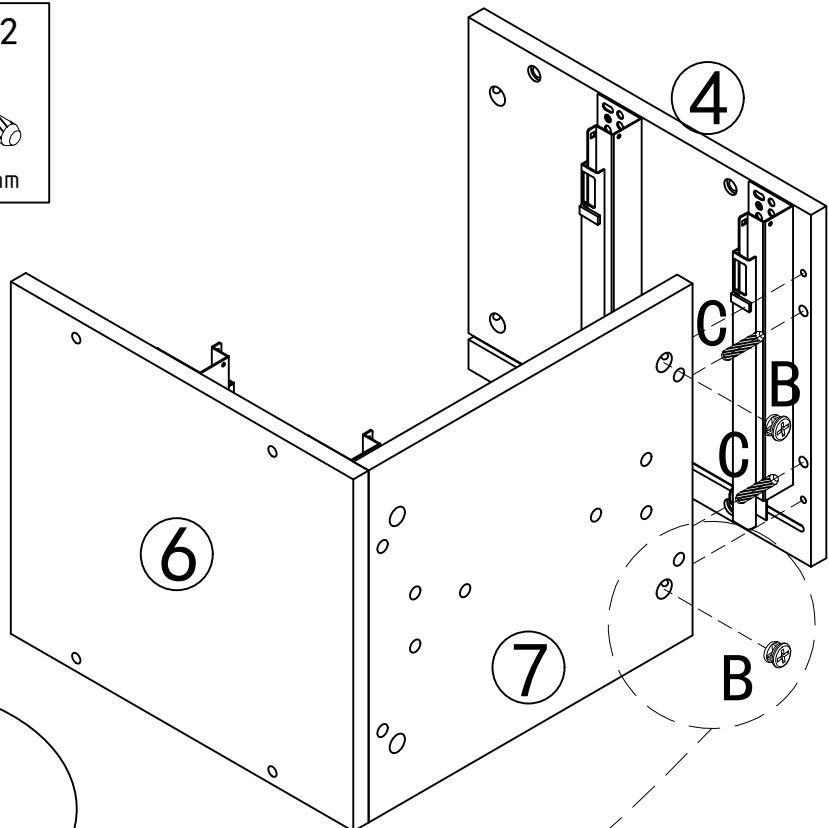
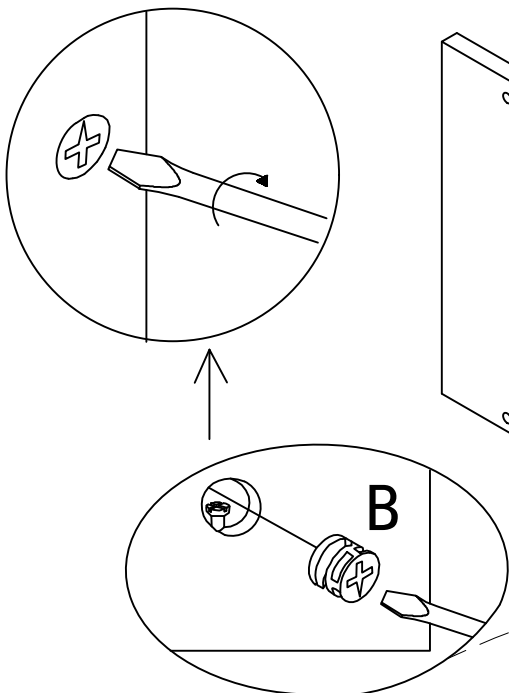
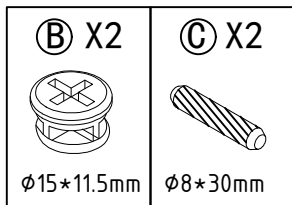

Step:4

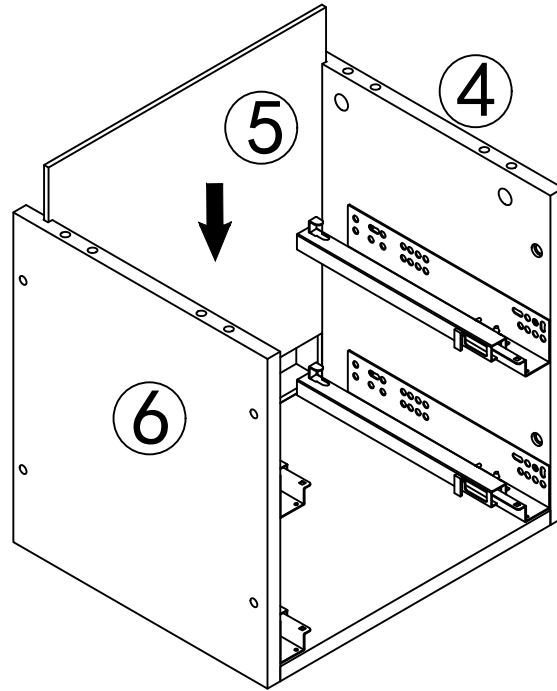
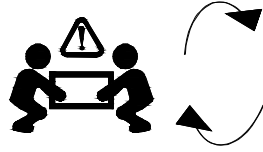

Step:5





Step:6

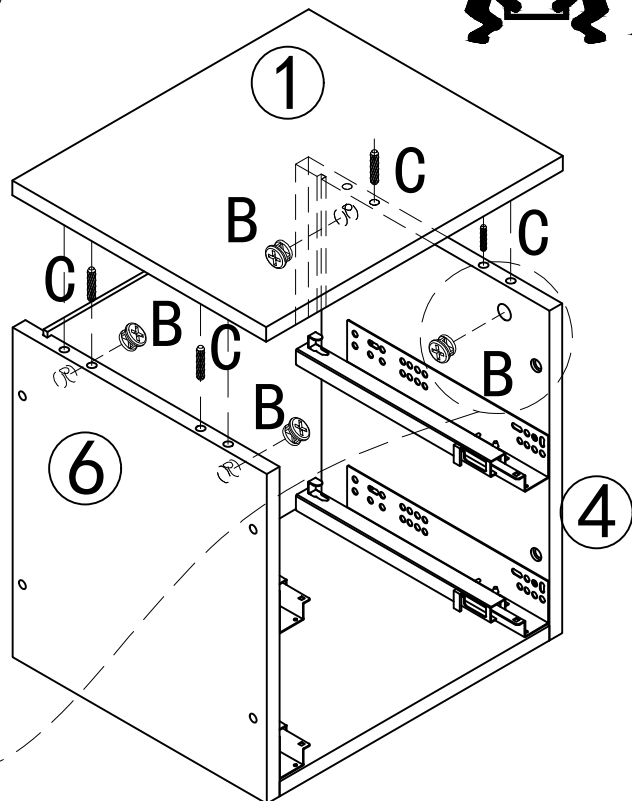
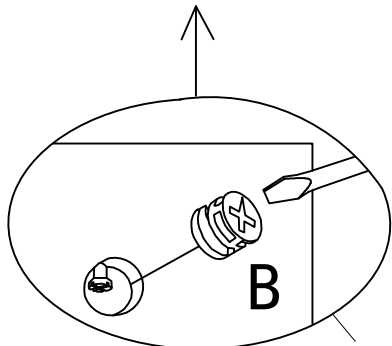
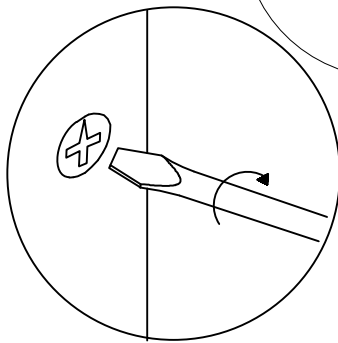
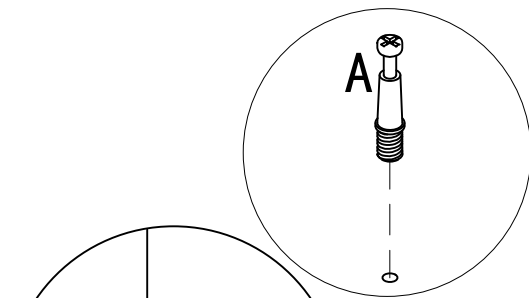
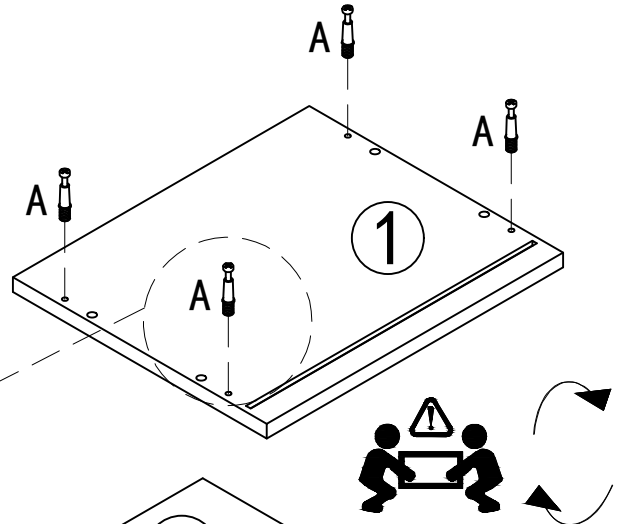

<b>A</b> X4	<b>B</b> X4	<b>C</b> X4
		
	$\phi 15 \times 11.5 \text{mm}$	$\phi 8 \times 30 \text{mm}$



Step:7

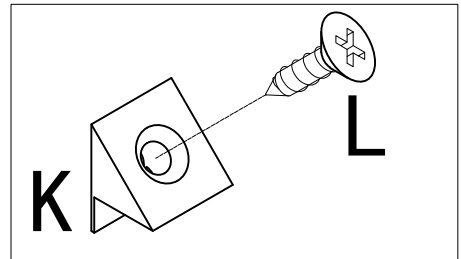
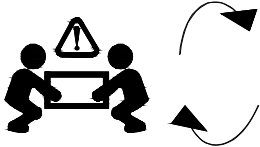
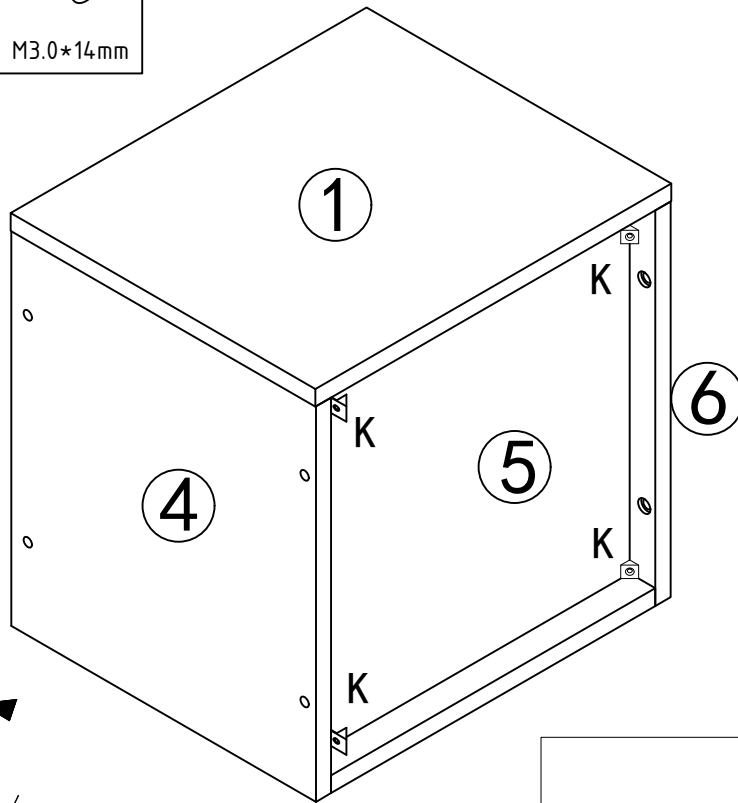

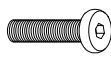
<b>K</b> X4 	<b>L</b> X4  M3.0*14mm
--	---



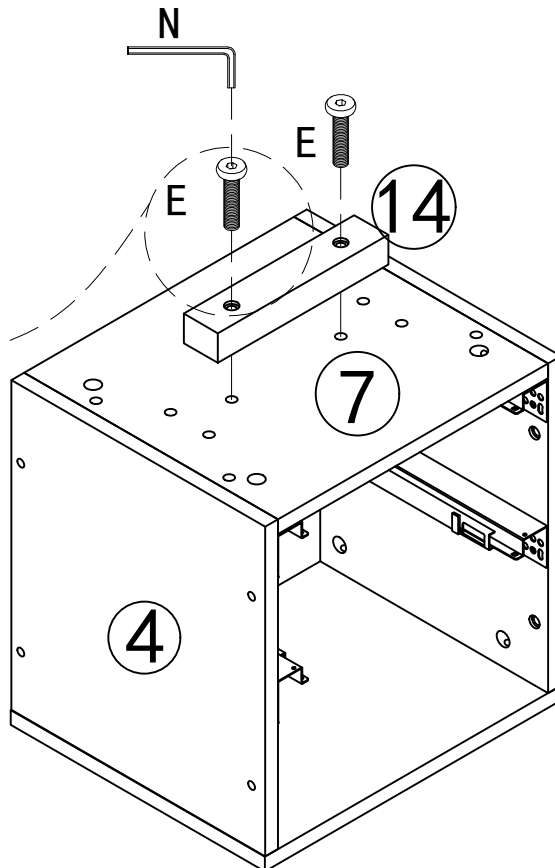
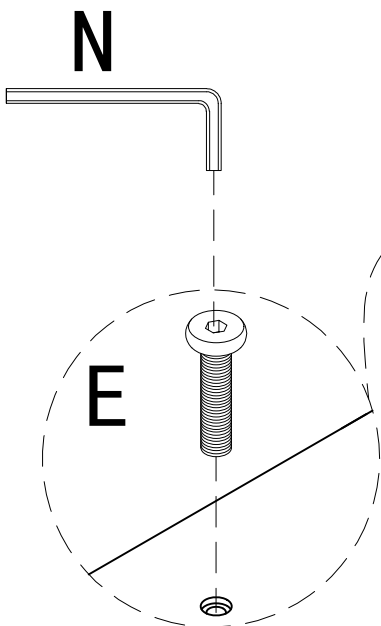

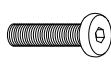

<b>E</b> X2  M6*38mm	<b>N</b> X1 
---	--

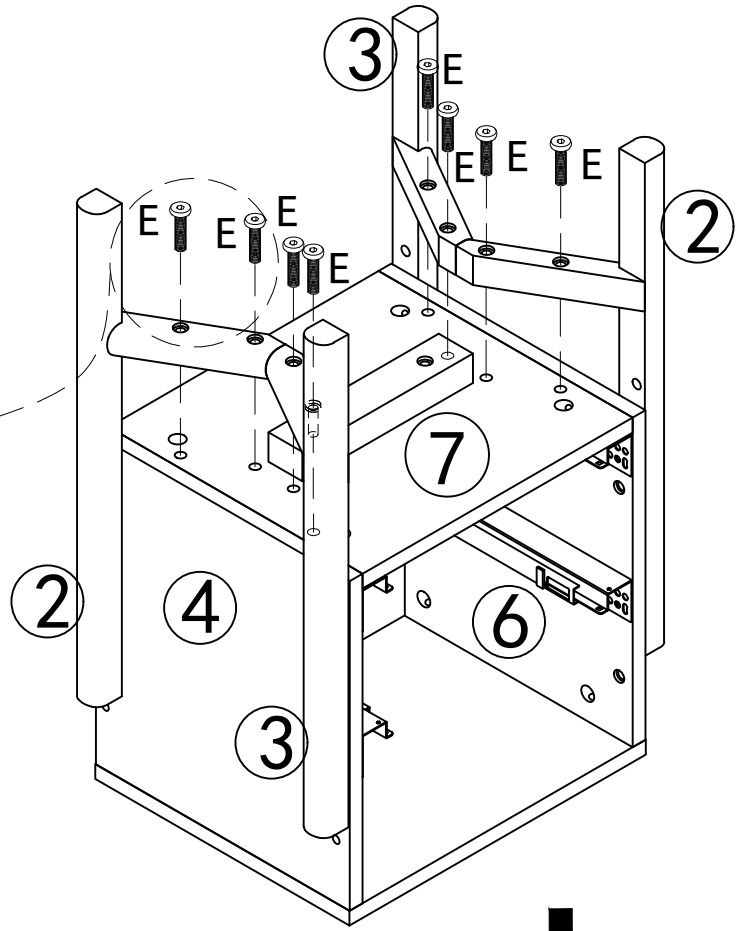
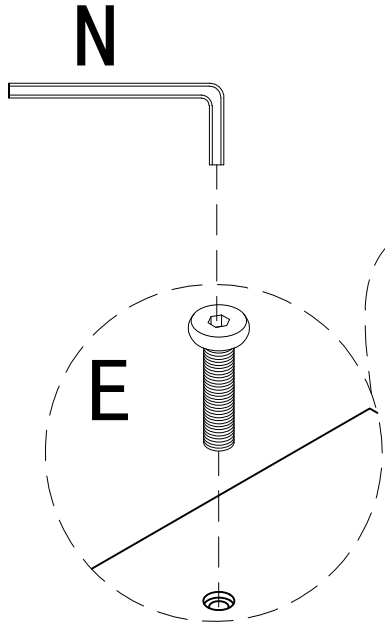

Step:8

<b>(E)</b> X8	<b>(N)</b> X1
	
M6*38mm	



<b>(F)</b> X4	<b>(N)</b> X1	<b>(M)</b> X4
		
M6*20mm		25*25*3mm

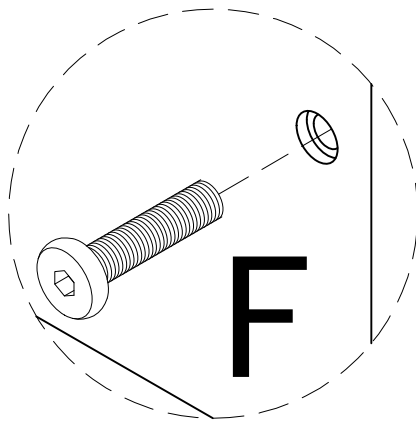
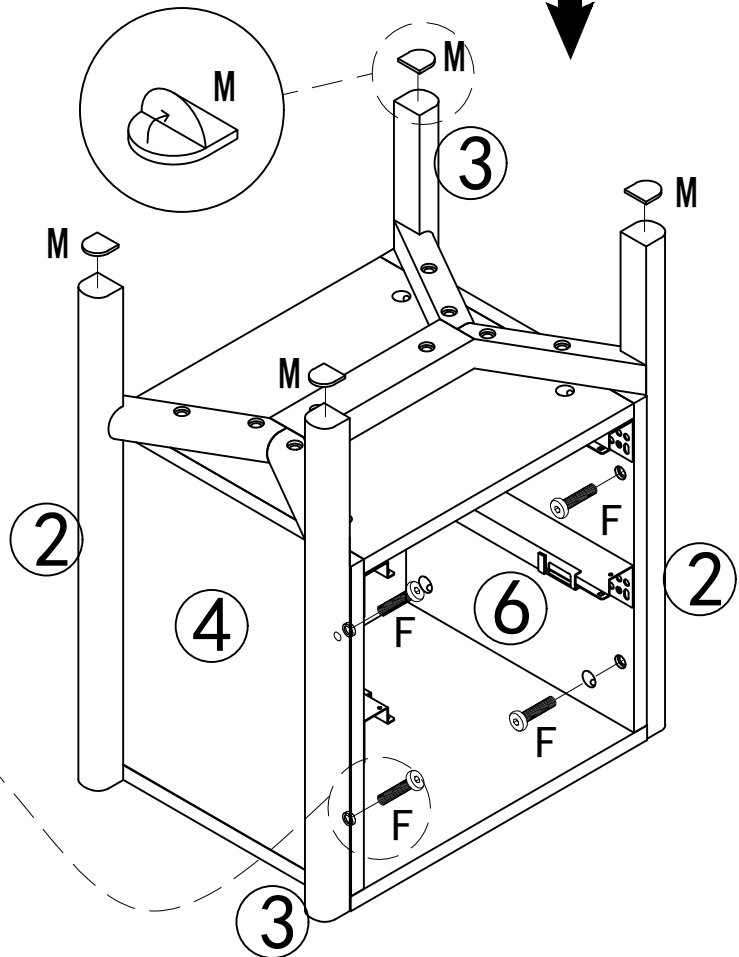

Step:9

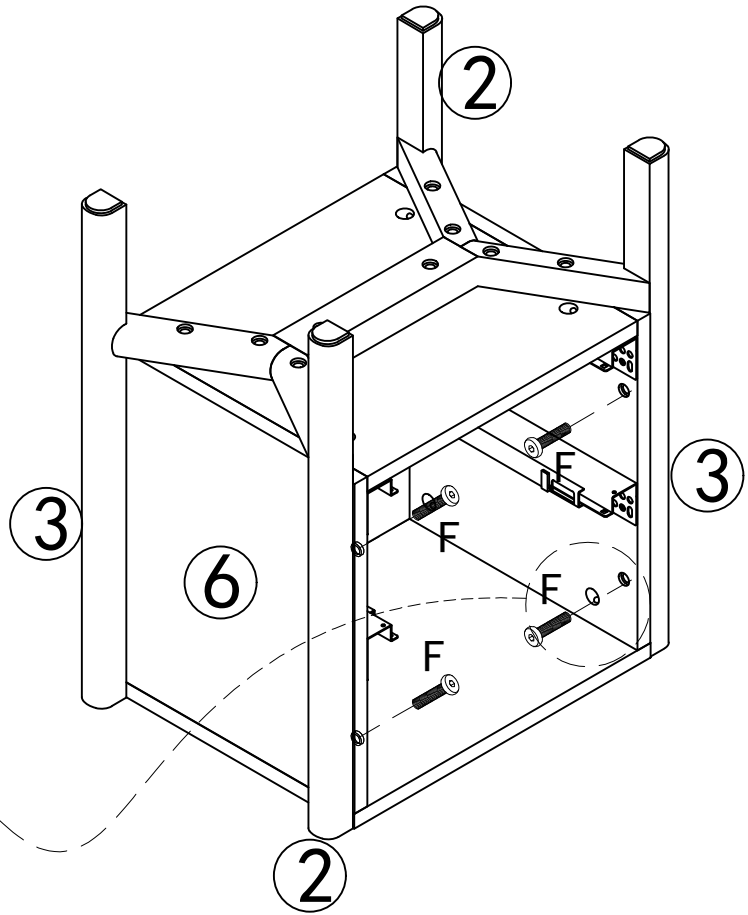
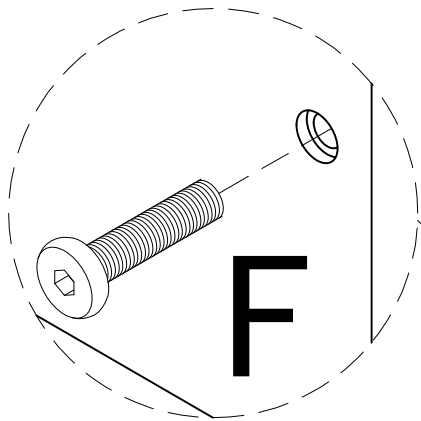
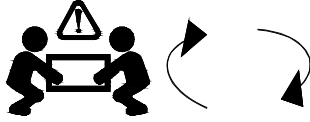
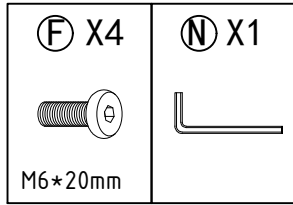

Step:10

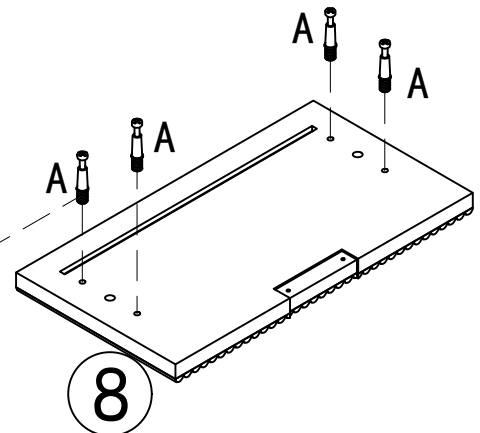
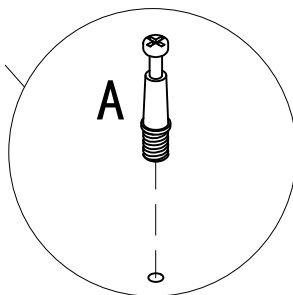
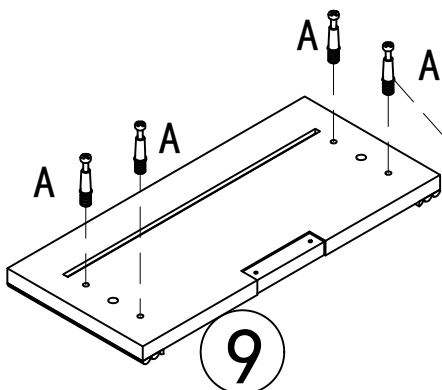
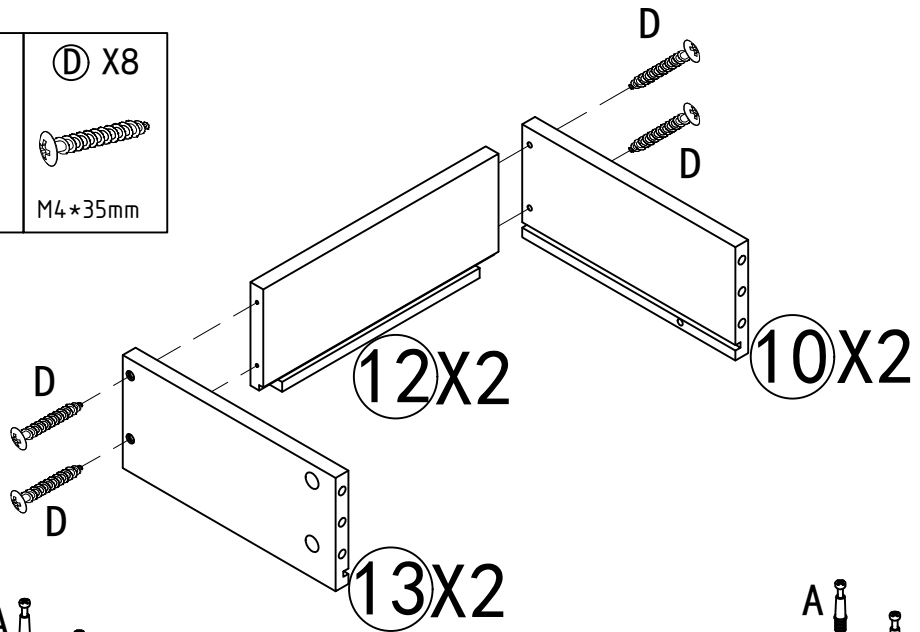
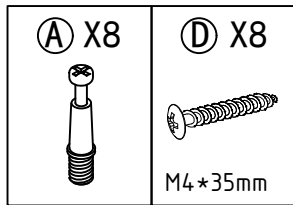

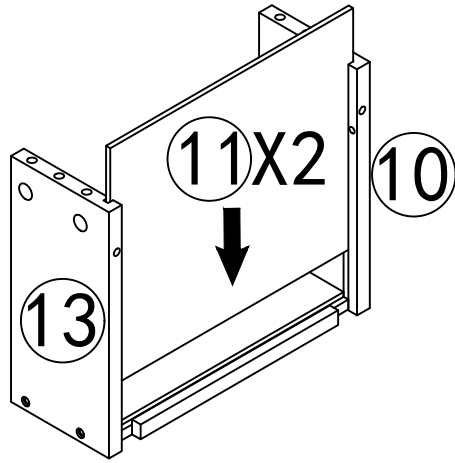

Step:11

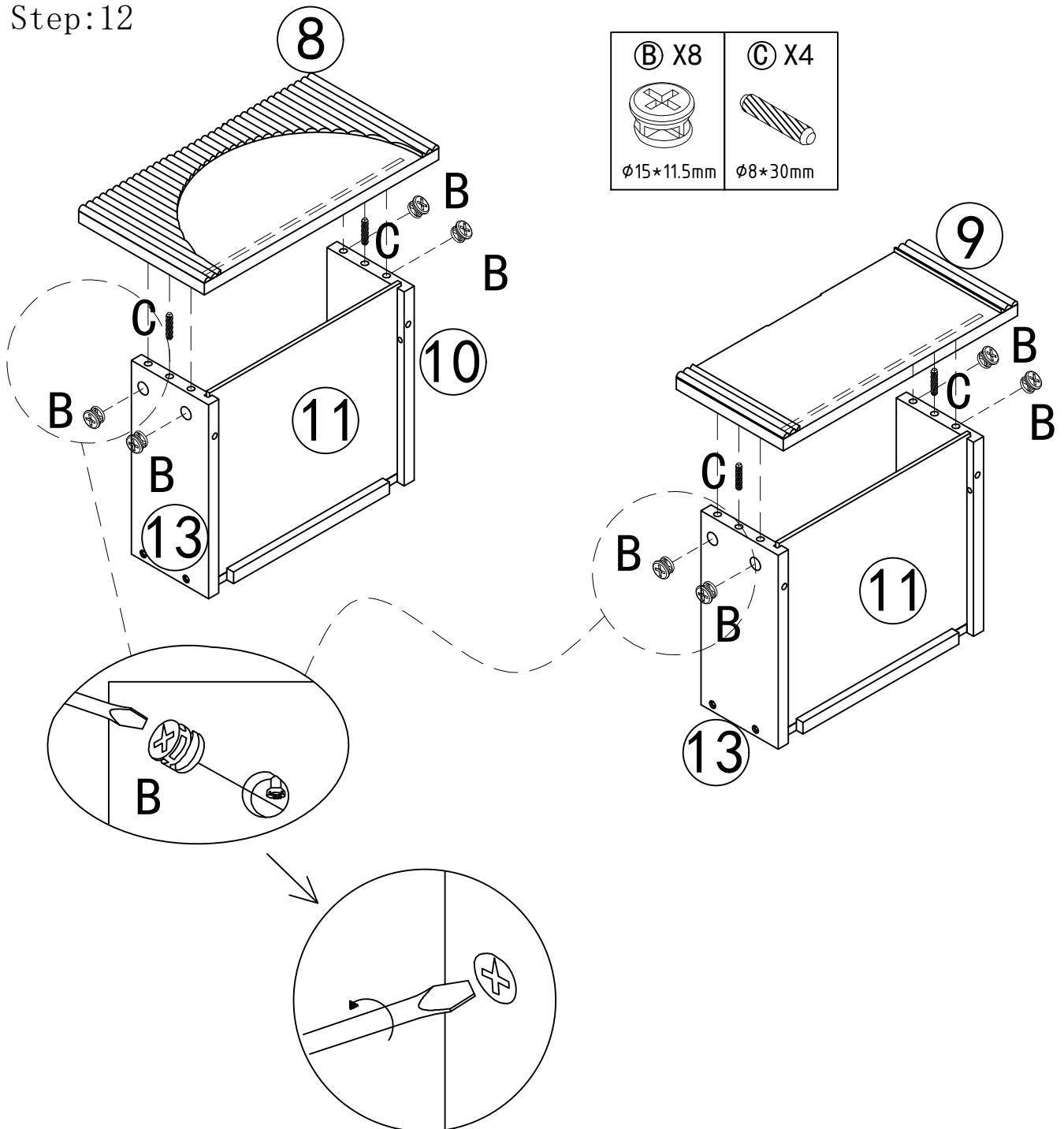

Step:12

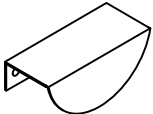

# Step:13

<b>G</b> X2	<b>H</b> X4
	
	M3.5*14mm

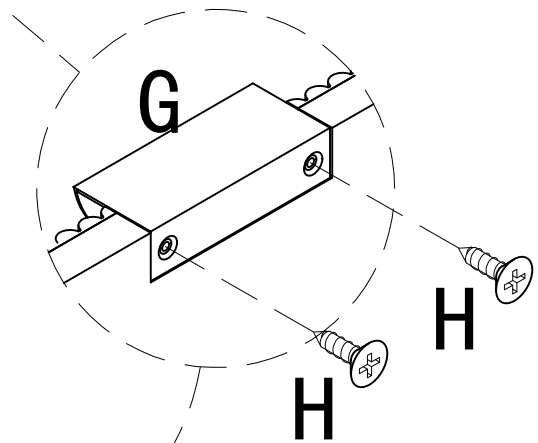
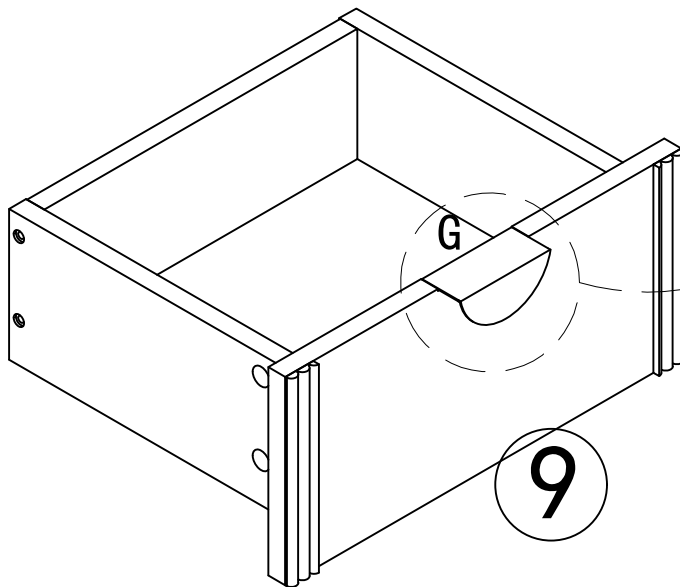
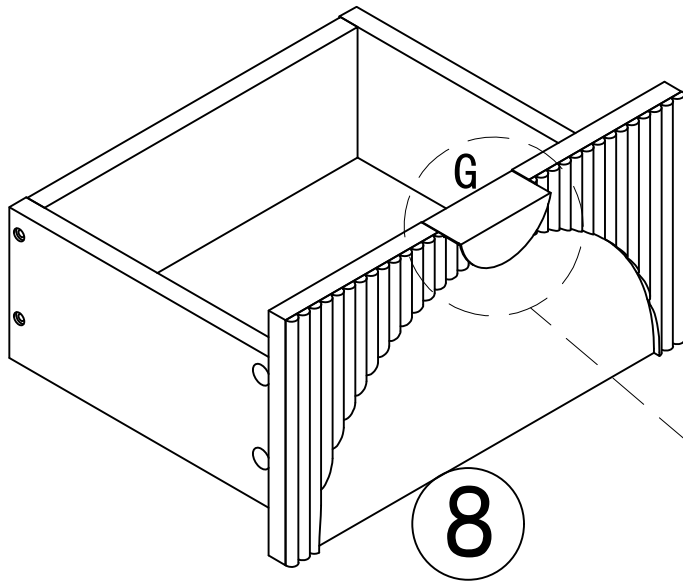

Step:14

